

It is necessary to adjust ring gear end play, countershaft bearing preload, hypoid gear and hypoid pinion height, front differential case end play when replacing any part in chart below.

Adjustment Application Chart

X: Necessary Blank: Not necessary					
Determine the required adjustment					
Adjustment	Ring gear end play	Countershaft bearing preload	Hypoid gear height	Hypoid pinion height	Front differential case end play
Adjusting method	Ring gear snap ring	Countershaft shim and Hypoid gear shim	Hypoid gear shim	Pinion sleeve shim	Front differential side bearing adjusting shim
Replaced part					
Transfer case set (Transfer case, adapter plate and front cover)	X	X	X	X	X
Ring gear	X				X
Ring gear bearing	X				
Hypoid gear set (Hypoid gear and pinion)		X	X	X	
Countershaft		X			
Hypoid gear bearing		X	X	X	
Countershaft bearing		X			
Hypoid pinion bearing				X	
Pinion sleeve				X	
Front differential case					X
Front differential side bearing					X

Adjustment Procedure Chart

① SELECTION OF HYPOID GEAR SHIM

1. To simplify the adjustment, make a chart like the one below and write measurements on the chart.

FACTOR	HUNDREDTHS OF A MILLIMETER
A: Hypoid gear	
B: Hypoid gear bearing	

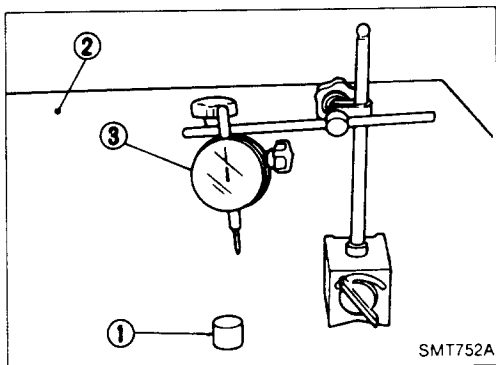

2. Measure hypoid gear bearing thickness.
- a. Prepare required tools for measurement.

- ① Master Gauge KV38101900
 ② Base Plate
 ③ Dial Indicator

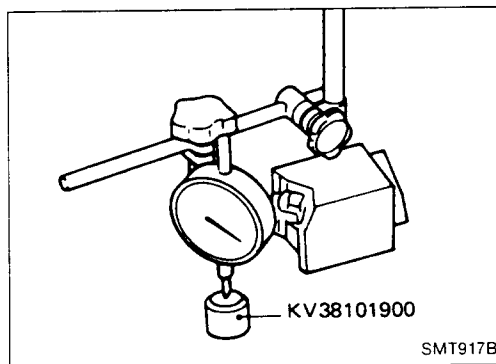

- b. Place dial indicator and master gauge on base plate.
 c. Place dial indicator on top of master gauge and then adjust dial indicator scale to zero.
 d. Carefully slide master gauge out from under dial indicator.

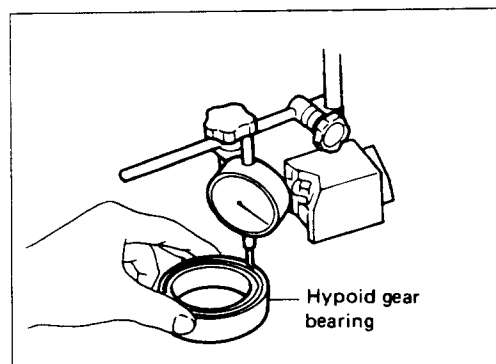

- e. Place hypoid gear bearing inner race on base plate and then place hypoid gear bearing outer race on inner race.
 f. Place dial indicator on top of outer race.
 g. Read dial indicator.

● **If the needle fluctuates erratically then bearing is either dirty or defective and should be cleaned or replaced.**

- h. Determine factor "B" to be used by the following equation.

$$B = \text{"Dial gauge deflection"} \times 100$$

[Bearing height = 20 mm (0.79 in) + Dial gauge deflection]

- i. Write "B" on chart.

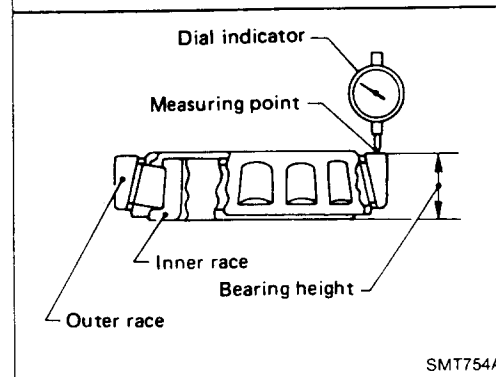

Adjustment Procedure Chart (Cont'd)

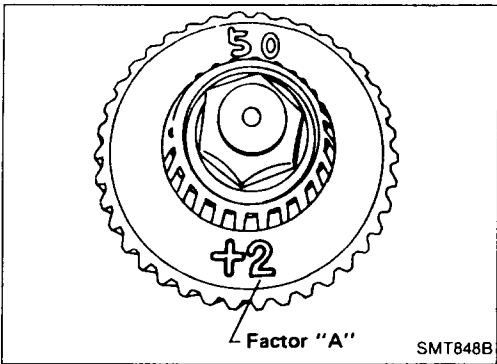

3. Write figure marked on hypoid gear as factor "A" on chart.
4. Determine dimension "C" to be used by the following equation.

$$C = 110 - A - B$$

FOR EXAMPLE

FACTOR	HUNDRETHS OF A MILLIMETER
A: Hypoid gear	2
B: Hypoid gear bearing	9 (0.09 × 100)

$$C = 110 - 2 - 9$$

$$= 99$$

Installation

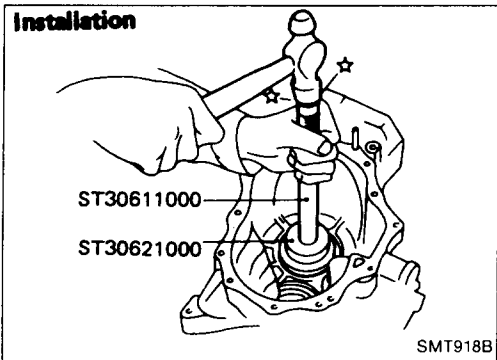

6. Select proper shims using S.D.S. table as a guide.
7. Install selected shims and hypoid gear bearing outer race (Transfer case side) in transfer case.

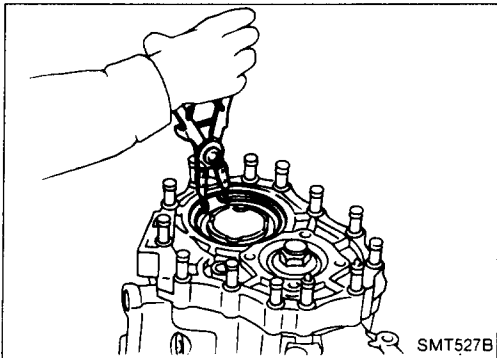

② REMOVAL OF RING GEAR SNAP RING

Removing ring gear snap ring.

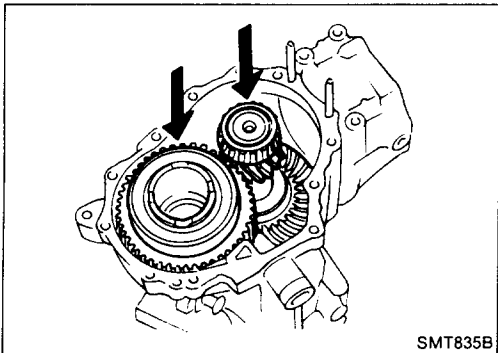

③ INSTALLATION OF RING GEAR, COUNTERSHAFT AND ADAPTER PLATE

1. Install ring gear and countershaft.
2. Install adapter plate.

Temporarily install spacers and tighten bolts to the specified torque.

Spacer: 25 mm (0.98 in)

Adjustment Procedure Chart (Cont'd)

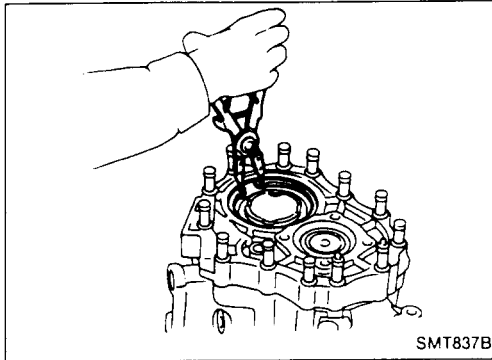
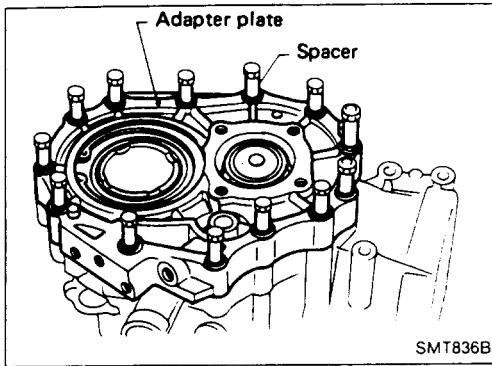

④ SELECTION OF RING GEAR SNAP RING

1. Install the thinnest snap ring [Part No. 33138-56E00, Thickness: 4.00 mm (0.1575 in)] in ring gear snap ring groove.

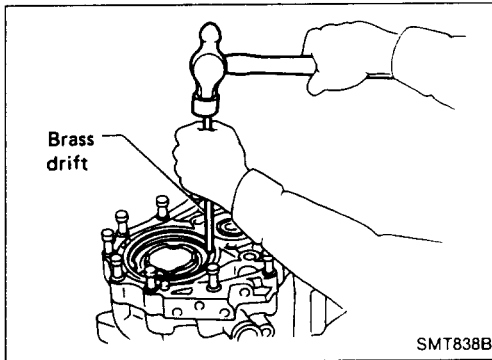

2. Tap ring gear snap ring lightly to seat it into groove.

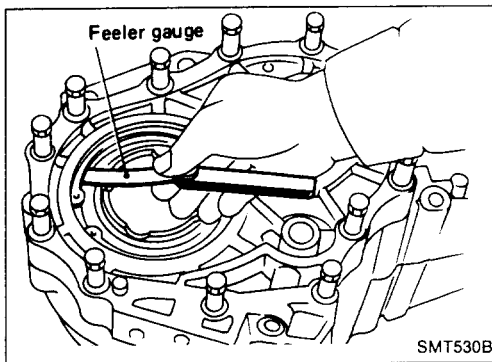

3. Measure clearance of groove.
4. Select proper snap ring using S.D.S. table as a guide.
5. Remove snap ring (Part No. 33138-56E00).
6. Install selected snap ring in ring gear snap ring groove.
7. Measure clearance of groove (ring gear end play) as a final check.

**Allowable clearance of groove
(Ring gear end play):**
0 - 0.06 mm (0 - 0.0024 in)

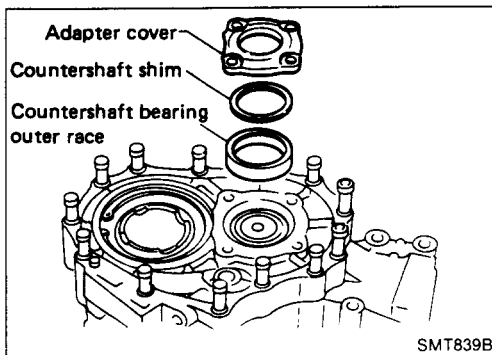

⑤ SELECTION OF COUNTERSHAFT SHIM

1. Remove adapter cover and countershaft shim.

Adjustment Procedure Chart (Cont'd)

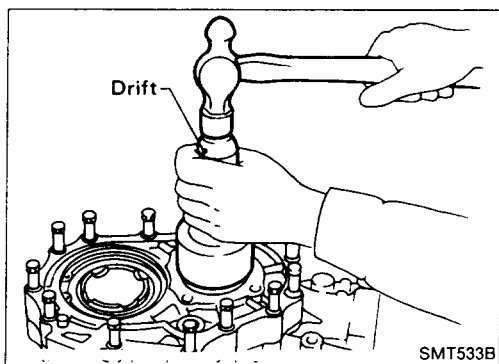

2. Tap countershaft bearing outer race lightly to seat bearings properly.

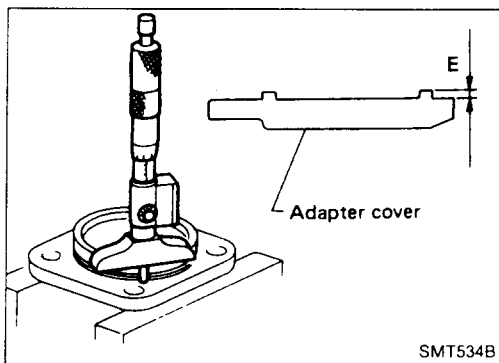

3. Measure factor "E".

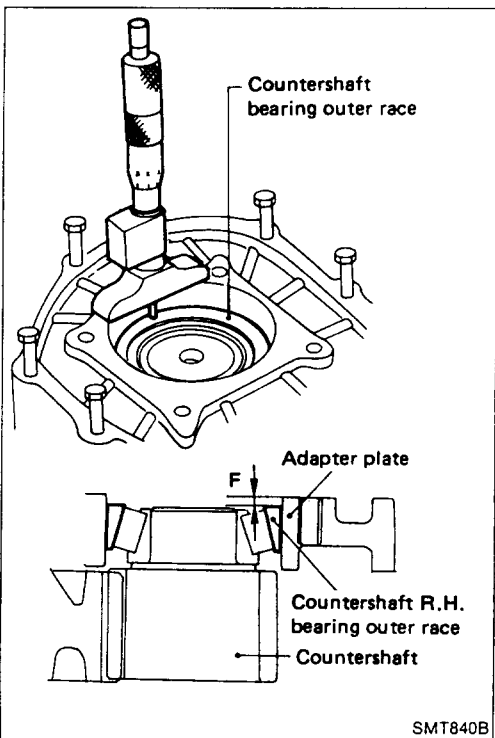

4. Measure factor "F".
5. Determine dimension "G" to be used by the following equation.

$$G = F - E$$

6. Select proper shims using S.D.S. table as a guide.
7. Install selected shims and adapter cover in adapter plate.

Tighten bolts to the specified torque.

8. Check countershaft preload as final check — Refer to "PRE-DISASSEMBLY INSPECTION".

If not within specification, select countershaft shim again.

⑥ SELECTION OF PINION SLEEVE SHIM

1. Install pinion sleeve assembly without O-ring and shim.

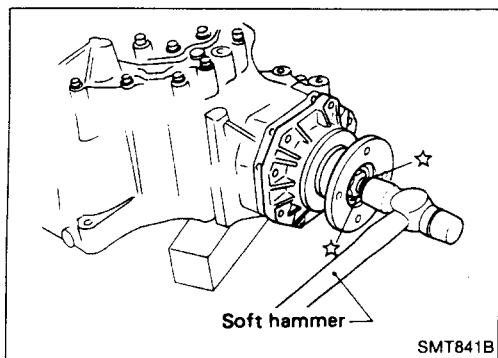

Adjustment Procedure Chart (Cont'd)

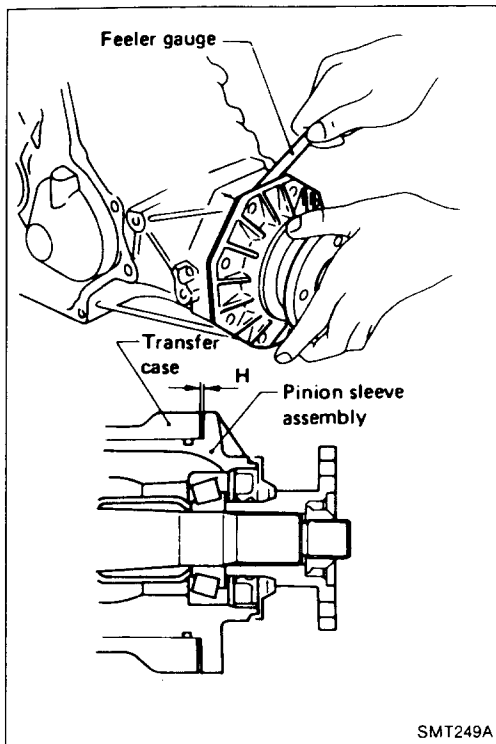

2. While pushing pinion sleeve assembly, measure clearance "H" between transfer case and pinion sleeve at least 4 points with feeler gauge.
3. Select proper shims using S.D.S. table as a guide.
4. Remove pinion sleeve assembly.

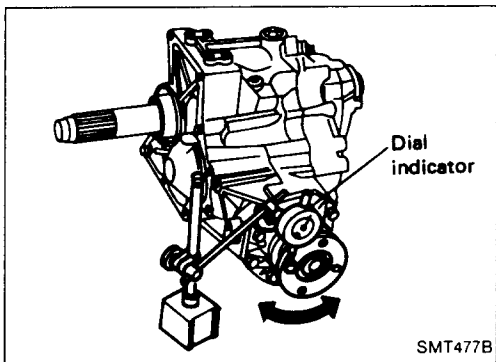

⑦ HYPOID GEAR-TO-PINION BACKLASH INSPECTION

1. Install pinion sleeve assembly with pinion sleeve shim.
2. Check hypoid gear-to-pinion backlash.

Hypoid gear-to-pinion backlash:
0.10 - 0.15 mm (0.0039 - 0.0059 in)

- If backlash is too small, decrease thickness of hypoid gear shim and increase thickness of countershaft shim by the same amount.
- If backlash is too great, reverse the above procedure.

Never change the total amount of shims as it will change the bearing preload.

3. Remove pinion sleeve assembly.

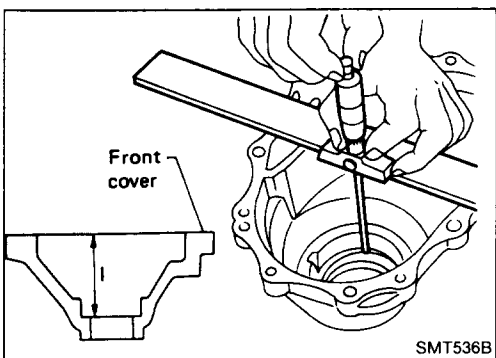

⑧ SELECTION OF FRONT DIFFERENTIAL SIDE BEARING SHIM

1. Measure factor "l".

Adjustment Procedure Chart (Cont'd)

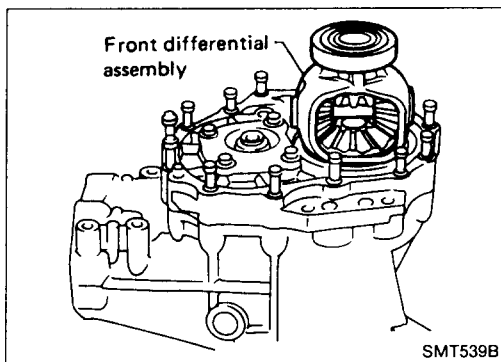

2. Install front differential assembly in adapter plate.

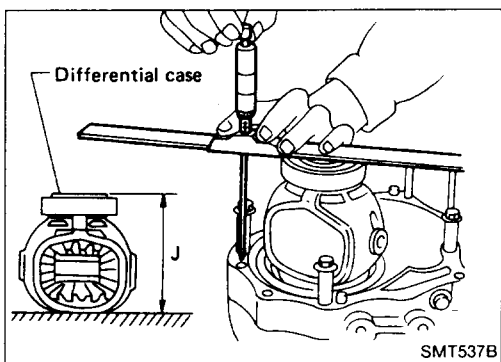

3. Measure factor "J".

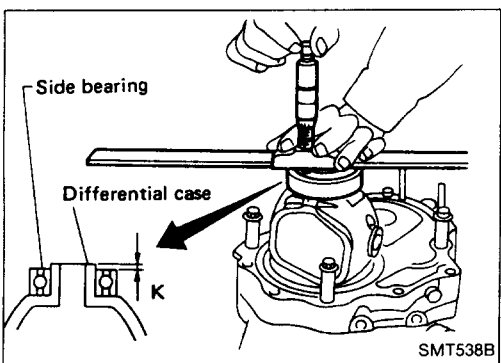

4. Measure factor "K".

Front differential case end play (I - J + K):
0.05 - 0.20 mm (0.0020 - 0.0079 in)

Select proper shims using S.D.S. table as a guide.

5. Install front cover.

⑨ **TOOTH CONTACT INSPECTION** — Refer to "TOOTH CONTACT".

Usually tooth contact pattern will be correct if you have selected the shims accurately.

However, in extremely rare cases you will have to use trial-and-error processes until the tooth contact pattern is right.

The tooth pattern is the best indication of how well a hypoid gear and pinion have been set up.

⑩ **REMOVAL OF ADAPTER COVER**

⑪ **REMOVAL OF FRONT COVER, FRONT DIFFERENTIAL, ADAPTER PLATE, RING GEAR AND COUNTER-SHAFT**

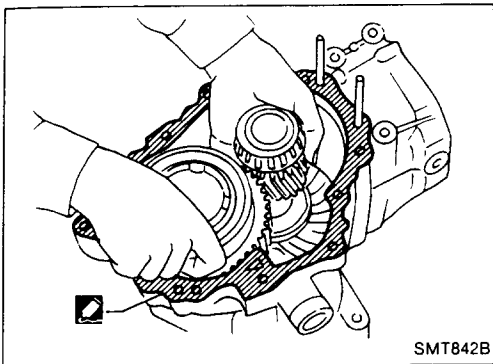

1. Install countershaft and ring gear as a set.
2. Clean adapter plate and transfer case mating surface.
3. Apply recommended sealant to transfer case and adapter plate mating surface.

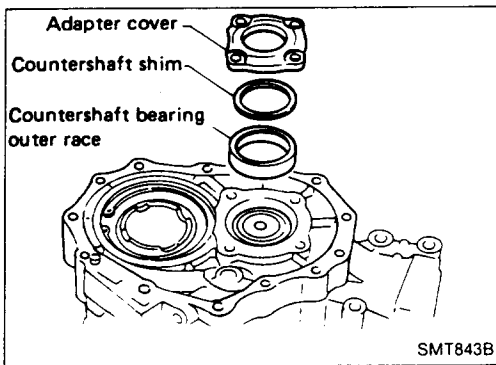

4. Install adapter plate.
5. Install countershaft bearing, countershaft shim and adapter cover.

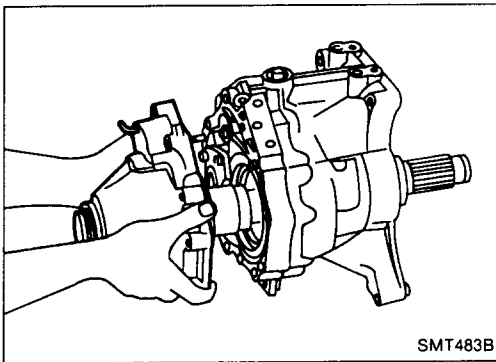

6. Install front differential assembly and front cover.

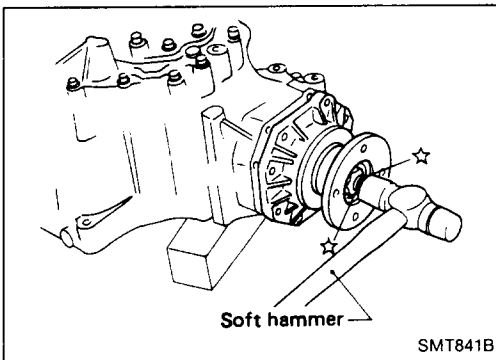

7. Install O-ring on pinion sleeve and then install pinion sleeve shim and pinion sleeve.
8. Install front cover oil seal.

SERVICE DATA AND SPECIFICATIONS (S.D.S.)

General Specifications

Vehicle model	GA16DS engine models	SR20DET engine models
Transfer model	VTY10A	FTY10A
Gear ratio	0.270	0.270
Number of teeth	Ring gear	47
	Counter gear	21
	Hypoid gear	38
	Hypoid pinion	23
Oil capacity ℓ (Imp qt)	1.1 (1)	1.5 (1-3/8)

Inspection and Adjustment

GEAR END PLAY (VTY10A & FTY10A)

Unit: mm (in)

Ring gear	0 - 0.06 (0 - 0.0024)
-----------	-----------------------

BEARING PRELOAD (VTY10A & FTY10A)

Hypoid pinion bearing	Adjusting method		Collapsible spacer	
	Preload	N·m (kg-cm, in-lb) *2		1.1 - 1.6 (11 - 16, 9.5 - 13.9)
Counter-shaft bearing	Adjusting method		Shim (countershaft shim and hypoid gear shim)	
	Preload	N (kg, lb)*1		88 - 235 (9 - 24, 20 - 53)
		mm (in)		0.20 - 0.26 (0.0079 - 0.0102)
Total pre-load	N·m (kg-cm, in-lb) *2	2.0 - 3.9 (20 - 40, 17 - 35)		

*1: at right gear spline outer diameter

*2: at pinion nut

GEAR BACKLASH

Unit: mm (in)

Transfer model	VTY10A	FTY10A
Ring gear-to-counter gear*1	0.02 - 0.04 (0.0008 - 0.0016)	0.02 - 0.04 (0.0008 - 0.0016)
Hypoid gear-to-pinion*2	0.08 - 0.12 (0.0031 - 0.0047)*2	0.10 - 0.15 (0.0039 - 0.0059)*3

*1: at ring gear spline

*2: at bolt hole in viscous coupling

*3: at bolt hole of companion flange

AVAILABLE SHIMS

Countershaft shims

Thickness mm (in)	Part number	
	VTY10A	FTY10A
0.40 (0.0157)	33123-06R00	33123-56E00
0.44 (0.0173)	33123-06R01	33123-56E01
0.48 (0.0189)	33123-06R02	33123-56E02
0.52 (0.0205)	33123-06R03	33123-56E03
0.56 (0.0220)	33123-06R04	33123-56E04
0.60 (0.0236)	33123-06R05	33123-56E05
0.64 (0.0252)	33123-06R06	33123-56E06
0.68 (0.0268)	33123-06R07	33123-56E07
0.72 (0.0283)	33123-06R08	33123-56E08
0.76 (0.0299)	33123-06R09	33123-56E09
0.92 (0.0362)	33123-06R10	33123-56E10
1.32 (0.0520)	33123-06R11	33123-56E11

SERVICE DATA AND SPECIFICATIONS (S.D.S.)

Inspection and Adjustment (Cont'd)

**Table for selecting suitable countershaft shim
(VTY10A & FTY10A)**

Unit: mm (in)

Unit: mm (in)		
Dimension "G"	Suitable shim thickness	Appropriate shim
0.31 - 0.35 (0.0122 - 0.0138)	0.56 (0.0220)	0.56 (0.0220)
0.35 - 0.39 (0.0138 - 0.0154)	0.60 (0.0236)	0.60 (0.0236)
0.39 - 0.43 (0.0154 - 0.0169)	0.64 (0.0252)	0.64 (0.0252)
0.43 - 0.47 (0.0169 - 0.0185)	0.68 (0.0268)	0.68 (0.0268)
0.47 - 0.51 (0.0185 - 0.0201)	0.72 (0.0283)	0.72 (0.0283)
0.51 - 0.55 (0.0201 - 0.0217)	0.76 (0.0299)	0.76 (0.0299)
0.55 - 0.59 (0.0217 - 0.0232)	0.80 (0.0315)	0.40 + 0.40 (0.0157 + 0.0157)
0.59 - 0.63 (0.0232 - 0.0248)	0.84 (0.0331)	0.40 + 0.44 (0.0157 + 0.0173)
0.63 - 0.67 (0.0248 - 0.0264)	0.88 (0.0346)	0.40 + 0.48 (0.0157 + 0.0189)
0.67 - 0.71 (0.0264 - 0.0280)	0.92 (0.0362)	0.92 (0.0362)
0.71 - 0.75 (0.0280 - 0.0295)	0.96 (0.0378)	0.40 + 0.56 (0.0157 + 0.0220)
0.75 - 0.79 (0.0295 - 0.0311)	1.00 (0.0394)	0.40 + 0.60 (0.0157 + 0.0236)
0.79 - 0.83 (0.0311 - 0.0327)	1.04 (0.0409)	0.40 + 0.64 (0.0157 + 0.0252)
0.83 - 0.87 (0.0327 - 0.0343)	1.08 (0.0425)	0.40 + 0.68 (0.0157 + 0.0268)
0.87 - 0.91 (0.0343 - 0.0358)	1.12 (0.0441)	0.40 + 0.72 (0.0157 + 0.0283)
0.91 - 0.95 (0.0358 - 0.0374)	1.16 (0.0457)	0.40 + 0.76 (0.0157 + 0.0299)
0.95 - 0.99 (0.0374 - 0.0390)	1.20 (0.0472)	0.44 + 0.76 (0.0173 + 0.0299)
0.99 - 1.03 (0.0390 - 0.0406)	1.24 (0.0488)	0.48 + 0.76 (0.0189 + 0.0299)
1.03 - 1.07 (0.0406 - 0.0421)	1.28 (0.0504)	0.52 + 0.76 (0.0205 + 0.0299)
1.07 - 1.11 (0.0421 - 0.0437)	1.32 (0.0520)	1.32 (0.0520)
1.11 - 1.15 (0.0437 - 0.0453)	1.36 (0.0535)	0.60 + 0.76 (0.0236 + 0.0299)
1.15 - 1.19 (0.0453 - 0.0469)	1.40 (0.0551)	0.64 + 0.76 (0.0252 + 0.0299)
1.19 - 1.23 (0.0469 - 0.0484)	1.44 (0.0567)	0.68 + 0.76 (0.0268 + 0.0299)
1.23 - 1.27 (0.0484 - 0.0500)	1.48 (0.0583)	0.72 + 0.76 (0.0283 + 0.0299)

Dimension "G"	Suitable shim thickness	Appropriate shim
1.27 - 1.31 (0.0500 - 0.0516)	1.52 (0.0598)	0.76 + 0.76 (0.0299 + 0.0299)
1.31 - 1.35 (0.0516 - 0.0531)	1.56 (0.0614)	0.64 + 0.92 (0.0252 + 0.0362)
1.35 - 1.39 (0.0531 - 0.0547)	1.60 (0.0630)	0.68 + 0.92 (0.0268 + 0.0362)
1.39 - 1.43 (0.0547 - 0.0563)	1.64 (0.0646)	0.72 + 0.92 (0.0283 + 0.0362)
1.43 - 1.47 (0.0563 - 0.0579)	1.68 (0.0661)	0.76 + 0.92 (0.0299 + 0.0362)
1.47 - 1.51 (0.0579 - 0.0594)	1.72 (0.0677)	0.40 + 1.32 (0.0157 + 0.0520)
1.51 - 1.55 (0.0594 - 0.0610)	1.76 (0.0693)	0.44 + 1.32 (0.0173 + 0.0520)
1.55 - 1.59 (0.0610 - 0.0626)	1.80 (0.0709)	0.48 + 1.32 (0.0189 + 0.0520)
1.59 - 1.63 (0.0626 - 0.0642)	1.84 (0.0724)	0.52 + 1.32 (0.0205 + 0.0520)
1.63 - 1.67 (0.0642 - 0.0657)	1.88 (0.0740)	0.56 + 1.32 (0.0220 + 0.0520)
1.67 - 1.71 (0.0657 - 0.0673)	1.92 (0.0756)	0.60 + 1.32 (0.0236 + 0.0520)
1.71 - 1.75 (0.0673 - 0.0689)	1.96 (0.0772)	0.64 + 1.32 (0.0252 + 0.0520)
1.75 - 1.79 (0.0689 - 0.0705)	2.00 (0.0787)	0.68 + 1.32 (0.0268 + 0.0520)
1.79 - 1.83 (0.0705 - 0.0720)	2.04 (0.0803)	0.72 + 1.32 (0.0283 + 0.0520)

SERVICE DATA AND SPECIFICATIONS (S.D.S.)

Inspection and Adjustment (Cont'd)

AVAILABLE SNAP RINGS

Ring gear snap rings

(VTY10A)

Unit: mm (in)

Thickness	Part number
3.00 (0.1181)	33138-10R00
3.04 (0.1197)	33138-10R01
3.08 (0.1213)	33138-10R02
3.12 (0.1228)	33138-10R03
3.16 (0.1244)	33138-10R04
3.20 (0.1260)	33138-10R05
3.24 (0.1276)	33138-10R06
3.28 (0.1291)	33138-10R07
3.32 (0.1307)	33138-10R08
3.36 (0.1323)	33138-10R09
3.40 (0.1339)	33138-10R10
3.44 (0.1354)	33138-10R11
3.48 (0.1370)	33138-10R12
3.52 (0.1386)	33138-10R13
3.56 (0.1402)	33138-10R14
3.60 (0.1417)	33138-10R15
3.64 (0.1433)	33138-10R16

(FTY10A)

Unit: mm (in)

Thickness	Part number
4.00 (0.1575)	33138-56E00
4.04 (0.1591)	33138-56E01
4.08 (0.1606)	33138-56E02
4.12 (0.1622)	33138-56E03
4.16 (0.1638)	33138-56E04
4.20 (0.1654)	33138-56E05
4.24 (0.1669)	33138-56E06
4.28 (0.1685)	33138-56E07
4.32 (0.1701)	33138-56E08
4.36 (0.1717)	33138-56E09
4.40 (0.1732)	33138-56E10
4.44 (0.1748)	33138-56E11
4.48 (0.1764)	33138-56E12
4.52 (0.1780)	33138-56E13
4.56 (0.1795)	33138-56E14
4.60 (0.1811)	33138-56E15
4.64 (0.1827)	33138-56E16

Table for selecting suitable ring gear snap ring

(VTY10A)

Unit: mm (in)

Measured clearance	Thickness of suitable snap ring
0.00 - 0.04 (0.0000 - 0.0016)	3.00 (0.1181)
0.04 - 0.08 (0.0016 - 0.0031)	3.04 (0.1197)
0.08 - 0.12 (0.0031 - 0.0047)	3.08 (0.1213)
0.12 - 0.16 (0.0047 - 0.0063)	3.12 (0.1228)
0.16 - 0.20 (0.0063 - 0.0079)	3.16 (0.1244)
0.20 - 0.24 (0.0079 - 0.0094)	3.20 (0.1260)
0.24 - 0.28 (0.0094 - 0.0110)	3.24 (0.1276)
0.28 - 0.32 (0.0110 - 0.0126)	3.28 (0.1291)
0.32 - 0.36 (0.0126 - 0.0142)	3.32 (0.1307)
0.36 - 0.40 (0.0142 - 0.0157)	3.36 (0.1323)
0.40 - 0.44 (0.0157 - 0.0173)	3.40 (0.1339)
0.44 - 0.48 (0.0173 - 0.0189)	3.44 (0.1354)
0.48 - 0.52 (0.0189 - 0.0205)	3.48 (0.1370)
0.52 - 0.56 (0.0205 - 0.0220)	3.52 (0.1386)
0.56 - 0.60 (0.0220 - 0.0236)	3.56 (0.1402)
0.60 - 0.64 (0.0236 - 0.0252)	3.60 (0.1417)
0.64 - 0.68 (0.0252 - 0.0268)	3.64 (0.1433)

(FTY10A)

Unit: mm (in)

Measured clearance	Thickness of suitable snap ring
0.00 - 0.04 (0.0000 - 0.0016)	4.00 (0.1575)
0.04 - 0.08 (0.0016 - 0.0031)	4.04 (0.1591)
0.08 - 0.12 (0.0031 - 0.0047)	4.08 (0.1606)
0.12 - 0.16 (0.0047 - 0.0063)	4.12 (0.1622)
0.16 - 0.20 (0.0063 - 0.0079)	4.16 (0.1638)
0.20 - 0.24 (0.0079 - 0.0094)	4.20 (0.1654)
0.24 - 0.28 (0.0094 - 0.0110)	4.24 (0.1669)
0.28 - 0.32 (0.0110 - 0.0126)	4.28 (0.1685)
0.32 - 0.36 (0.0126 - 0.0142)	4.32 (0.1701)
0.36 - 0.40 (0.0142 - 0.0157)	4.36 (0.1717)
0.40 - 0.44 (0.0157 - 0.0173)	4.40 (0.1732)
0.44 - 0.48 (0.0173 - 0.0189)	4.44 (0.1748)
0.48 - 0.52 (0.0189 - 0.0205)	4.48 (0.1764)
0.52 - 0.56 (0.0205 - 0.0220)	4.52 (0.1780)
0.56 - 0.60 (0.0220 - 0.0236)	4.56 (0.1795)
0.60 - 0.64 (0.0236 - 0.0252)	4.60 (0.1811)
0.64 - 0.68 (0.0252 - 0.0268)	4.64 (0.1827)

SERVICE DATA AND SPECIFICATIONS (S.D.S.)

Inspection and Adjustment (Cont'd)

Hypoid gear shims (VTY10A & FTY10A)

Unit: mm (in)

Thickness	Part number
0.40 (0.0157)	33147-06R00
0.44 (0.0173)	33147-06R01
0.48 (0.0189)	33147-06R02
0.60 (0.0236)	33147-06R03
0.64 (0.0252)	33147-06R04
0.68 (0.0268)	33147-06R06
0.72 (0.0283)	33147-06R07
0.76 (0.0299)	33147-06R05

Table for selecting suitable hypoid gear shim

(VTY10A)

Unit: mm (in)

Dimension "D"	Suitable shim thickness	Appropriate shim
70 - 74 (2.76 - 2.91)	0.80 (0.0315)	0.40 + 0.40 (0.0157 + 0.0157)
74 - 78 (2.91 - 3.07)	0.84 (0.0331)	0.40 + 0.44 (0.0157 + 0.0173)
78 - 82 (3.07 - 3.23)	0.88 (0.0346)	0.40 + 0.48 (0.0157 + 0.0189)
82 - 86 (3.23 - 3.39)	0.92 (0.0362)	0.44 + 0.48 (0.0173 + 0.0189)
86 - 90 (3.39 - 3.54)	0.96 (0.0378)	0.48 + 0.48 (0.0189 + 0.0189)
90 - 94 (3.54 - 3.70)	1.00 (0.0394)	0.40 + 0.60 (0.0157 + 0.0236)
94 - 98 (3.70 - 3.86)	1.04 (0.0409)	0.44 + 0.60 (0.0173 + 0.0236)
98 - 102 (3.86 - 4.02)	1.08 (0.0425)	0.48 + 0.60 (0.0189 + 0.0236)
102 - 106 (4.02 - 4.17)	1.12 (0.0441)	0.48 + 0.64 (0.0189 + 0.0252)
106 - 110 (4.17 - 4.33)	1.16 (0.0457)	0.48 + 0.68 (0.0189 + 0.0268)
110 - 114 (4.33 - 4.49)	1.20 (0.0472)	0.48 + 0.72 (0.0189 + 0.0283)

(FTY10A)

Unit: mm (in)

Dimension "C"	Suitable shim thickness	Appropriate shim
78 - 81 (3.07 - 3.19)	0.80 (0.0315)	0.40 + 0.40 (0.0157 + 0.0157)
82 - 85 (3.23 - 3.35)	0.84 (0.0331)	0.40 + 0.44 (0.0157 + 0.0173)
86 - 89 (3.39 - 3.50)	0.88 (0.0346)	0.40 + 0.48 (0.0157 + 0.0189)
90 - 93 (3.54 - 3.66)	0.92 (0.0362)	0.44 + 0.48 (0.0173 + 0.0189)
94 - 97 (3.70 - 3.82)	0.96 (0.0378)	0.48 + 0.48 (0.0189 + 0.0189)
98 - 101 (3.86 - 3.98)	1.00 (0.0394)	0.40 + 0.60 (0.0157 + 0.0236)
102 - 105 (4.02 - 4.13)	1.04 (0.0409)	0.44 + 0.60 (0.0173 + 0.0236)
106 - 109 (4.17 - 4.29)	1.08 (0.0425)	0.48 + 0.60 (0.0189 + 0.0236)
110 - 113 (4.43 - 4.45)	1.12 (0.0441)	0.48 + 0.64 (0.0189 + 0.0252)
114 - 117 (4.49 - 4.61)	1.16 (0.0457)	0.48 + 0.68 (0.0189 + 0.0268)
118 - 121 (4.65 - 4.76)	1.20 (0.0472)	0.48 + 0.72 (0.0189 + 0.0283)

SERVICE DATA AND SPECIFICATIONS (S.D.S.)

Inspection and Adjustment (Cont'd)

Pinion sleeve shims (VTY10A & FTY10A)

Unit: mm (in)

Thickness	Part number
0.40 (0.0157)	33155-10R00
0.44 (0.0173)	33155-10R01
0.48 (0.0189)	33155-10R02
0.52 (0.0205)	33155-10R03
0.56 (0.0220)	33155-10R04
0.60 (0.0236)	33155-10R05
0.64 (0.0252)	33155-10R06
0.68 (0.0268)	33155-10R07
0.72 (0.0283)	33155-10R08
0.76 (0.0299)	33155-10R09

Table for selecting suitable pinion sleeve shim

(VTY10A & FTY10A)

Unit: mm (in)

Dimension "H"	Suitable shim thickness	Appropriate shim
0.64 - 0.67 (0.0252 - 0.0264)	0.84 (0.0331)	0.40 + 0.44 (0.0157 + 0.0173)
0.68 - 0.71 (0.0268 - 0.0280)	0.88 (0.0346)	0.40 + 0.48 (0.0157 + 0.0189)
0.72 - 0.75 (0.0283 - 0.0295)	0.92 (0.0362)	0.40 + 0.52 (0.0157 + 0.0205)
0.76 - 0.79 (0.0299 - 0.0311)	0.96 (0.0378)	0.40 + 0.56 (0.0157 + 0.0220)
0.80 - 0.83 (0.0315 - 0.0327)	1.00 (0.0394)	0.40 + 0.60 (0.0157 + 0.0236)
0.84 - 0.87 (0.0331 - 0.0343)	1.04 (0.0409)	0.40 + 0.64 (0.0157 + 0.0252)
0.88 - 0.91 (0.0346 - 0.0358)	1.08 (0.0425)	0.40 + 0.68 (0.0157 + 0.0268)
0.92 - 0.95 (0.0362 - 0.0374)	1.12 (0.0441)	0.40 + 0.72 (0.0157 + 0.0283)
0.96 - 0.99 (0.0378 - 0.0390)	1.16 (0.0457)	0.40 + 0.76 (0.0157 + 0.0299)
1.00 - 1.03 (0.0394 - 0.0406)	1.20 (0.0472)	0.44 + 0.76 (0.0173 + 0.0299)
1.04 - 1.07 (0.0409 - 0.0421)	1.24 (0.0488)	0.48 + 0.76 (0.0189 + 0.0299)
1.08 - 1.11 (0.0425 - 0.0437)	1.28 (0.0504)	0.52 + 0.76 (0.0205 + 0.0299)
1.12 - 1.15 (0.0441 - 0.0453)	1.32 (0.0520)	0.56 + 0.76 (0.0220 + 0.0299)
1.16 - 1.19 (0.0457 - 0.0469)	1.36 (0.0535)	0.60 + 0.76 (0.0236 + 0.0299)
1.20 - 1.23 (0.0472 - 0.0484)	1.40 (0.0551)	0.64 + 0.76 (0.0252 + 0.0299)
1.24 - 1.27 (0.0488 - 0.0500)	1.44 (0.0567)	0.68 + 0.76 (0.0268 + 0.0299)
1.28 - 1.31 (0.0504 - 0.0516)	1.48 (0.0583)	0.72 + 0.76 (0.0283 + 0.0299)
1.32 - 1.35 (0.0520 - 0.0531)	1.52 (0.0598)	0.76 + 0.76 (0.0299 + 0.0299)

Front differential side bearing adjusting shims

(FTY10A only)

Unit: mm (in)

Side bearing end play	0.05 - 0.20 (0.0020 - 0.0079)
Thickness mm (in)	Part number
0.40 (0.0157)	33147-06R00
0.44 (0.0173)	33147-06R01
0.48 (0.0189)	33147-06R02
0.60 (0.0236)	33147-06R03
0.64 (0.0252)	33147-06R04
0.68 (0.0268)	33147-06R06
0.72 (0.0283)	33147-06R07
0.76 (0.0299)	33147-06R05

AVAILABLE WASHERS

Front differential side gear thrust washers

(FTY10A only)

Unit: mm (in)

Clearance between side gear and differential case	0.1 - 0.2 (0.004 - 0.008)
Thickness mm (in)	Part number
0.75 - 0.80 (0.0295 - 0.0315)	38424-E3000
0.80 - 0.85 (0.0315 - 0.0335)	38424-E3001
0.85 - 0.90 (0.0335 - 0.0354)	38424-E3002
0.90 - 0.95 (0.0354 - 0.0374)	38424-E3003